

High density storage systems

BT radioshuttle

RS150



High density storage system

Shuttle specifications					RS150		
Pallet size*				mm	800x1200	1000x1200	1200x1200
Identification	1.2	Model			RS150	RS150	RS150
	1.3	Drive			Electric	Electric	Electric
	1.4	Type of operation			Rail guided shuttle	Rail guided shuttle	Rail guided shuttle
	1.5	Load capacity/rated load	Q	kg	1500	1500	1500
	1.6	Load centre	c	mm	450	550	650
	1.9	Wheel base	y	mm	500	700	900
Weight	2.1	Service weight including battery acc to 6.5		kg	220	250	280
Wheels	3.1	Drive/support wheels			Elathane	Elathane	Elathane
	3.2	Wheels size, front		mm	100	100	100
	3.3	Wheel size, rear		mm	100	100	100
	3.5	Wheels, number front/rear (x=driven wheels)			2/2/x	2/2/x	2/2/x
Dimensions	4.4	Lift height	h_3	mm	22	22	22
	4.7	Overall height	h_1	mm	208	208	208
	4.19	Overall length*	l_1	mm	900	1100	1300
	4.21	Overall width*	b_1	mm	1022	1022	1022
	4.22	Lift surface dimensions	e/l	mm	85/760	85/960	85/1160
		Width between fork	b_5	mm	300	300	300
		Fork channel	b_{20}	mm	295	295	295
		Pallet width*	K	mm	1200	1200	1200
		Pallet length*	L	mm	800	1000	1200
Performance	5.1	Travel speed, with/without load		m/s	$0,7/ \leq 1,1$	$0,7/ \leq 1,1$	$0,7/ \leq 1,1$
	5.2	Lift speed, with/without load		s	1,5	1,5	1,5
	5.3	Lowering speed, with/without rated load		s	1,5	1,5	1,5
Electric motor	6.1	Drive motor rating S2 60 min		kW	0,23	0,23	0,23
	6.2	Lift motor rating S3 15%		kW	0,23	0,23	0,23
	6.4	Battery voltage, nominal capacity K_5		V/Ah	24/50	24/50	24/50
	6.5	Battery weight		kg	2x24	2x24	2x24
Others	8.1	Type of drive control			Variable AC	Variable AC	Variable AC
	8.4	Sound level at the driver's ear acc to EN12 053		dB(A)	<70	<70	<70
Radio transmitter		Frequency		MHz	433	433	433
		Power supply		V/mA	12-24 DC/100	12-24 DC/100	12-24 DC/100
		Battery			9V alkaline battery type no: 6LR61		

*) Other alternatives are available

All data are based on table configuration. Other configurations may give other values.
Performance and dimensions are nominal and subject to tolerances.
BT products and specifications are subject to change without notice.

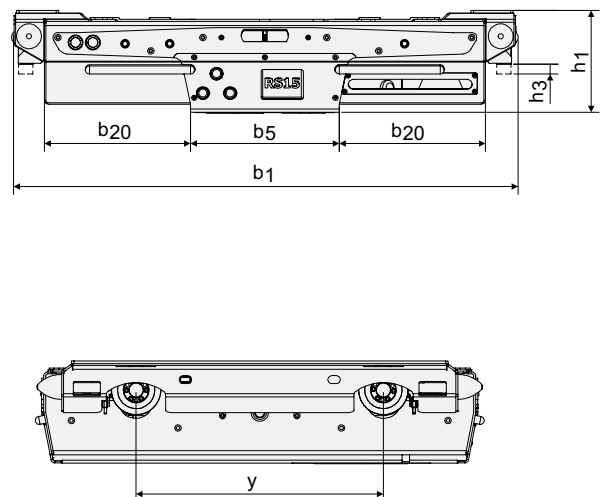
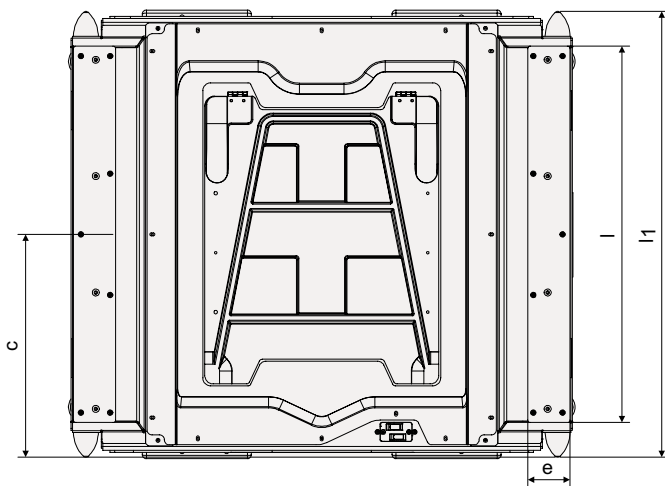

BT radioshuttle

Frontview levels racking system

- A Section dimension: 1350 mm *
- B Free dimension between rails: 922 mm *
- C Upright width 90 mm or 110 mm
- D Lowest level above floor 300 mm
- E Pallet height
- F Minimum distance between the pallets = 300 mm
- H Width over rail = 1148 mm *
- J Clearance = 9mm
- K Pallet width = 1200 mm *
- L Pallet depth

* Other dimensions possible

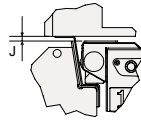
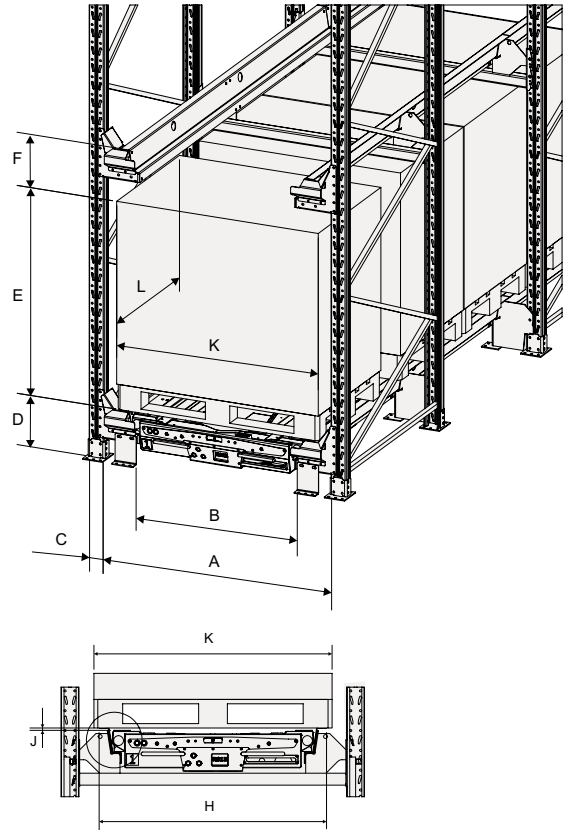

Sideview — depth of channel FiLo

(first in, last out)

- A Depth of channel 300mm +
(n x (pallet depth + 20mm))
- B Free space behind racking 150mm

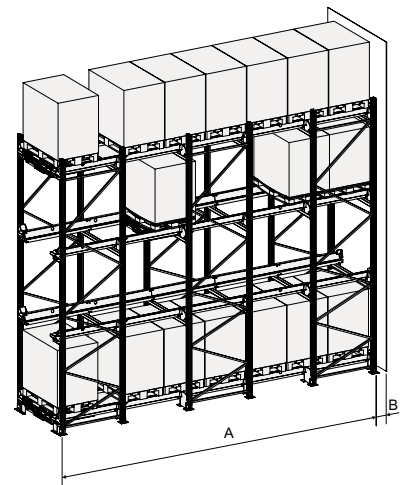

Sideview — depth of channel FiFo

(first in, first out)

- A Depth of channel 300mm +
(n x (pallet depth + 20mm)) + 300mm

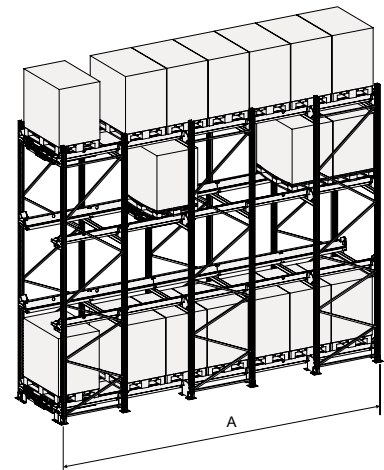

Shuttle system features:

- Proven system reliability with over 15 years of experience
- Improved storage utilization (more pallets on less space)
- Enable smaller SKU sizes
- More pallet movements in less time
- Virtually no goods damages
- Superior HMI functionality
- Inventory function
- Adaptive software design
- Pallet ordering system

